



PRINCIPAL TECHNICAL CHARACTERISTICS
CARACTERISTIQUES TECHNIQUES PRINCIPALES

- **Monobloc design in thermoplastic resin**
Conception monobloc en résine thermoplastique
- **Fire and smoke specification NFF 16-102 (requirement 3)**
Spécification Feu-fumée NFF 16-102 (exigence 3)
- **Electrical and environmental characteristics, in accordance with the relays characteristics**
Caractéristiques électriques et d'environnement, en accord avec les caractéristiques des relais
- **Hardware corrosion resistance steel**
Visserie en acier anti-corrosion
- **Crimp contacts in copper alloy**
Contacts à sertir en alliage de cuivre
- **Installation torque, relay 0.45Nm, socket on structure 0.6Nm**
Couple de serrage relais 0,45Nm, socle 0,6Nm
- **Socket sealing plug for SFE37X/SFE47X/SFE67X: 11 0596 00 rear insertion**
Obturbateurs pour socles SFE37X/SFE47X/SFE67X: 11 0596 00 insertion par l'arrière

Basic socket series designation for:
F370, F470, F570, F670, and timers.

DIMENSIONS
DIMENSIONS

Dimensions in mm
Tolerances, unless otherwise specified, ±0.25mm

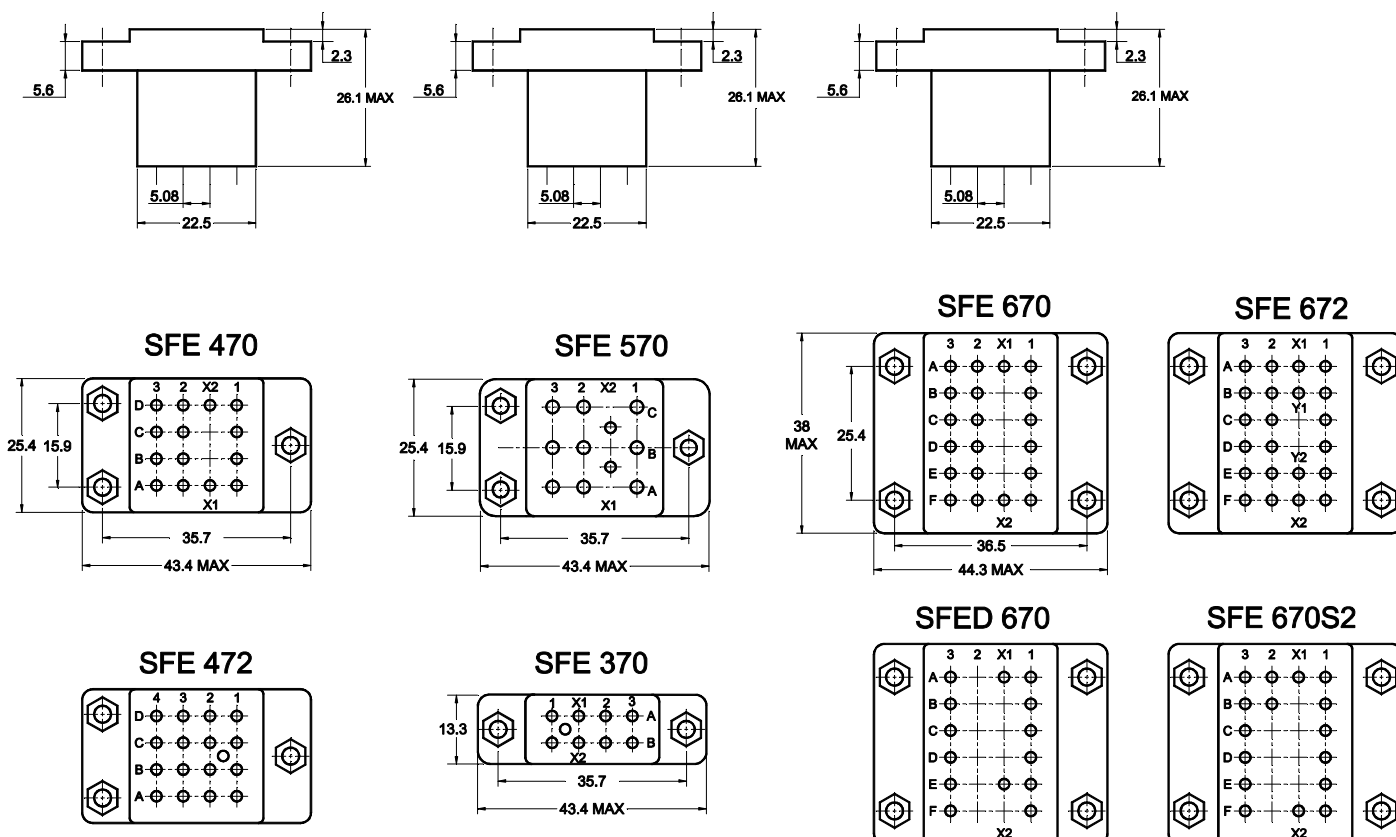

AMERICAS.
Tel: +1 714-736-7599
<http://www.esterline.com/powersystems>

EUROPE.
Tel: +33 3 87 97 31 01
Fax: +33 3 87 97 96 86

ASIA
Tel: +852 2 191 3830
Fax: +852 2 389 5803

MOUNTING
MONTAGE

Dimensions in mm
Tolerances, unless otherwise specified, ±0.25mm

KEY CODE
CLE DETROMPEE

STANDOFF KEY
ENTRETOISE

CODE 0: WITHOUT HARDWARE
SANS VISSERIE

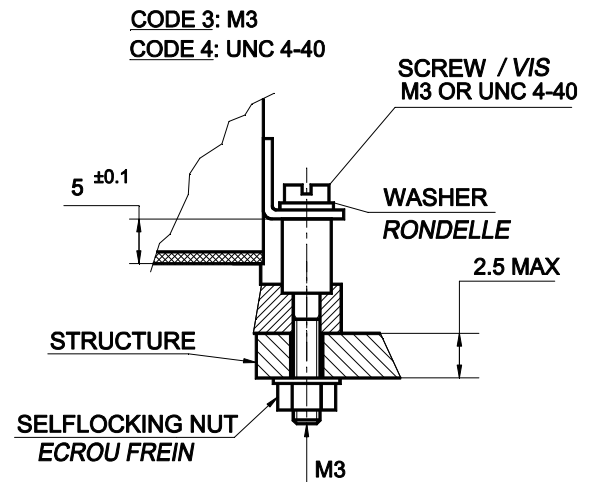
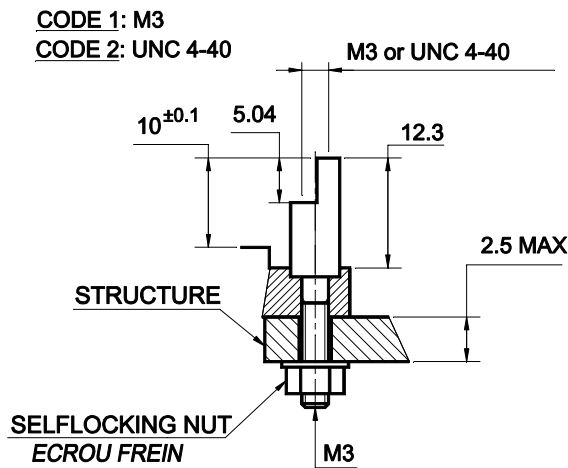

	0°	60°	120°	180°	240°	300°
	Code U	Code V	Code W	Code X	Code Y	Code Z
KEY 2						
KEY 3						
KEY 2						
KEY 2						
KEY 1						

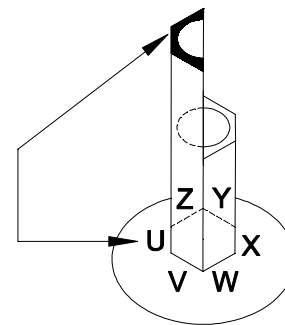

MOUNTING HOLE LAYOUT
DECOUPE DE LA STRUCTURE

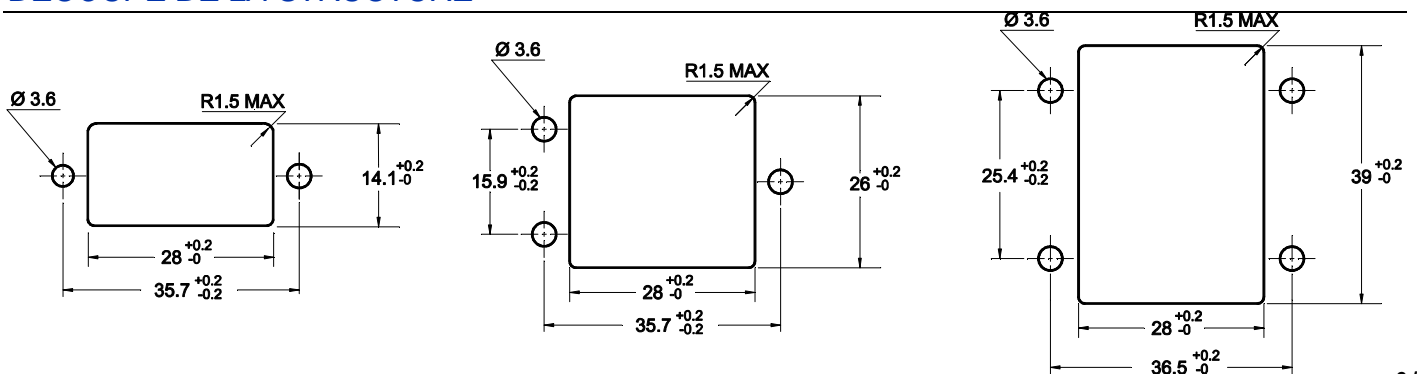

CONTACTS TYPE
TYPE CONTACTS

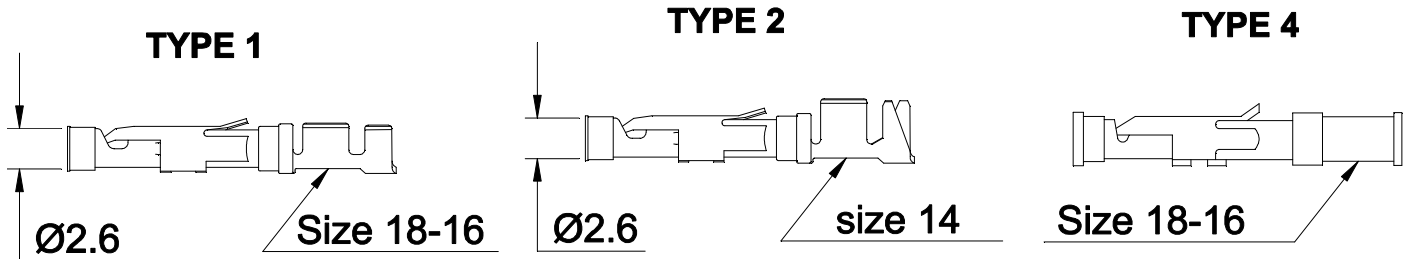

SFE37X / SFE47X / SFE67X

Insertion tool P/N: AMP 91002-1 - Extraction tool P/N: AMP 305183

Type 0	Without contacts
Type 1	Contacts 11 16 0306 (wire size 18-16). Crimping tool: P/N AMP 58945-2 or 91523-1 (size 18-16, wire section 0.75 to 1.50mm ²)
Type 2	Contacts 11 16 0307 (wire size 14). Crimping tool: P/N AMP 91521-1 (size 18-14, wire section 0.8 to 2.00mm ²)
Type 4	Contacts 11 16 0333 (wire size 18-16). Crimping tool: P/N AMP 91539-1 (size 18-16, wire section 0.8 to 1.40mm ²)

CODE 4

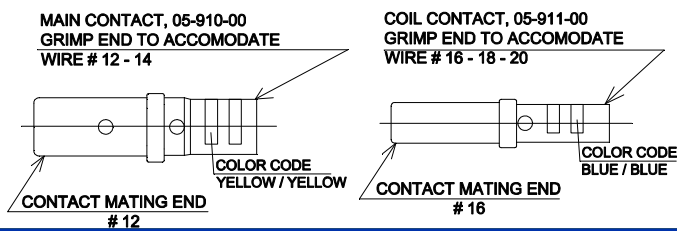

CODE 10

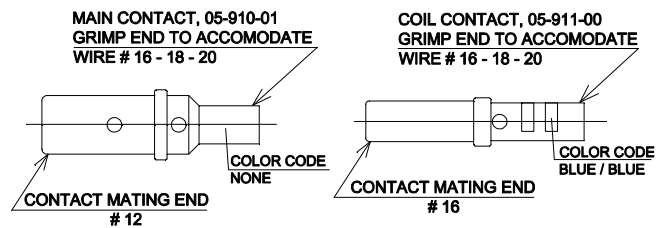

SFE570

Insertion and extraction tool: main: M81969/14-04 - coil: M81969/14-03

Crimping tool: M22520/1/01 with turret M22520/1-02 or MS 3191-1

Contact may be provided separately (using contacts P/N)

Type 4	Main contacts 05 910 00 (wire size 12-14) Coil contacts 05 911 00 (wire size 16-18-20)
Type 10	Main contacts 05 910 01 (wire size 16-18-20) Coil contacts 05 911 00 (wire size 16-18-20)

SOCKET NUMBERING SYSTEM
SYSTEME DE REFERENCES

Basic series designation | Référence de base

1. Socket series | Type de socle (370, 470, 570, D670)
2. Mounting hardware | Visserie
3. Contact type | Type de contact

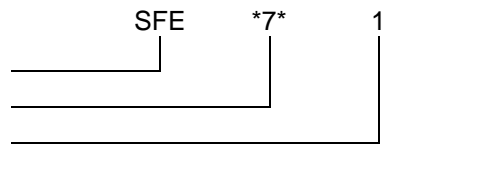

Exemple : SFE370-1-1