

Coil suppression module for:
Series SF401-1F, SF402-1F,
SF600-2F

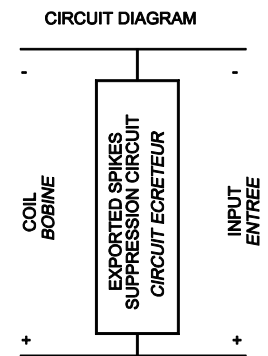
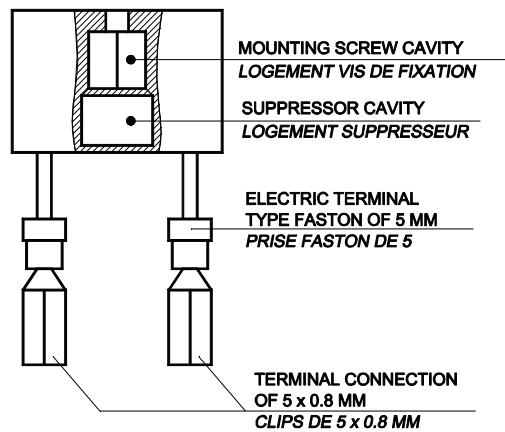

Dimensions in mm
Tolerances, unless otherwise specified, ±0.12mm

Note: The exported spikes suppression modules being bidirectional, the choice will be in accordance with the transitory power supply characteristics. Weight: 12.5 grams

Les écrêteurs étant bidirectionnels, le choix tiendra compte des caractéristiques transitoires de la tension d'alimentation.

Masse: 12.5 grammes.

GENERAL CHARACTERISTICS CARACTERISTIQUES GENERALES

Suppression module	Coil voltage	Suppression circuit
EC400-024V00	24V	1,5 KE43CA
EC400-072V02	72V	1,5 KE130CA
EC400-072V03	72V	1,5 KE150CA
EC400-072V04	72V	1,5 KE120CA
EC400-110V00	110V	1,5 KE200CA
EC400-110V01	110V	1,5 KE180CP

AMERICAS.

Tel: +1 714-736-7599

<http://www.esterline.com/powersystems>

EUROPE.

Tel: +33 3 87 97 31 01

Fax: +33 3 87 97 96 86

ASIA

Tel: +852 2 191 3830

Fax: +852 2 389 5803

MOUNTING MONTAGE

TOP MOUNT
MONTAGE SUR STRUCTURE

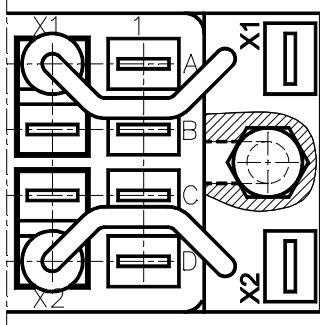

BOTTOM MOUNT
MONTAGE SOUS STRUCTURE

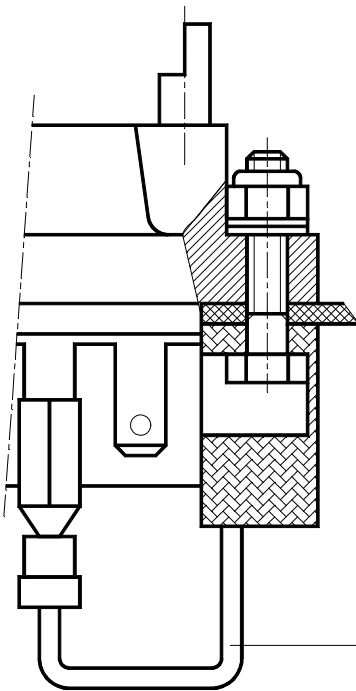
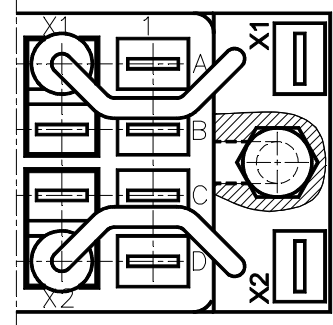

CABLE 0.93 WHITE E250 - 1 x 0.93 NF F 63 808
CABLE 0.93 BLANC E250 - 1 x 0.93 NF F 63 808

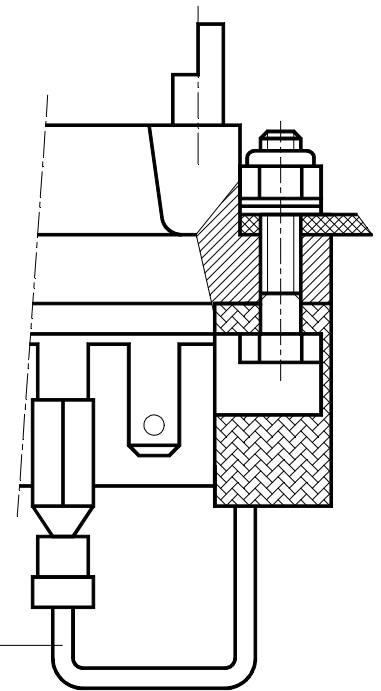

Note: The mounting hardware is supplied with socket, not with this module.

Note: Les fixations sont fournies avec l'embase, mais pas avec module écreteur.