

TOP MOUNT
MONTAGE SUR STRUCTURE

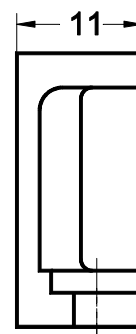

BOTTOM MOUNT
MONTAGE SOUS STRUCTURE

Basic socket series designation for:
SF400-1F, SF402-1F et SF600-2F

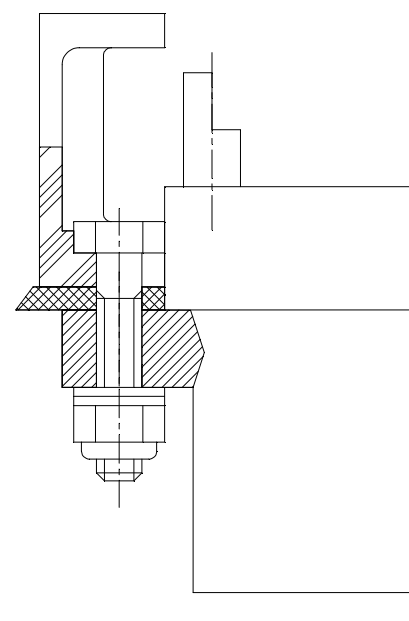
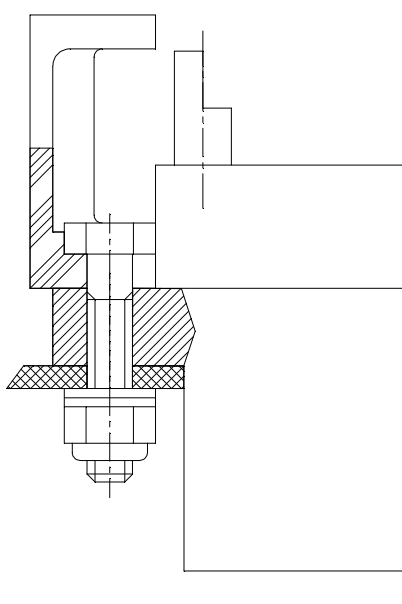

Dimensions in mm
Tolerances, unless otherwise specified, ± 0.12 mm

GENERAL CHARACTERISTICS CARACTERISTIQUES GENERALES

Material <i>Matière</i>	Lexan.
Weight <i>Poids</i>	5.2g max.
Label dimensions <i>Format de l'étiquette</i>	Thickness 0.5 mm.

Note: The mounting hardware is supplied with socket, not with the label holder.
Les fixations sont fournies avec l'embase, mais pas avec le porte étiquette.

AMERICAS.

Tel: +1 714-736-7599
<http://www.esterline.com/powersystems>

EUROPE.

Tel: +33 3 87 97 31 01
Fax: +33 3 87 97 96 86

ASIA

Tel: +852 2 191 3830
Fax: +852 2 389 5803