



Balanced-Force Design

Hermetically sealed

Designed to the performance standards of **MIL-PRF-6106**

PRINCIPLE TECHNICAL CHARACTERISTICS

Contacts rated at **28 Vdc and 115 Vac, 400 Hz, 1Ø and 115/200 Vac 400Hz, 3Ø**

Weight **See Mounting**

Special units available upon request, including models with auxiliary contacts. Optional Ground Fault Protection (GFP) feature available.

APPLICATION NOTES:

- [101](#)
- [102](#)
- [104](#)
- [105](#)
- [007](#)

CONTACT ELECTRICAL CHARACTERISTICS

Contact rating per pole and load type	Load current in Amps					
	28 Vdc	115 Vac 400 Hz	115/200 Vac 400 Hz, 3Ø	28 Vdc [3]	28 Vdc [8]	DELTA 115/200 Vac 60 Hz
Resistive [1]	50	120	120	120	200	60
Inductive [2]	30	120	120	80	-	60
Motor	30	80	80	80	-	60
Load transfer, resistive[7]	-	-	120	-	-	-



Featuring **LEACH®** power and control solutions
www.esterline.com

AMERICAS
 6900 Orangethorpe Ave.
 P.O. Box 5032
 Buena Park, CA 90622

Tel: (01) 714-736-7599
 Fax: (01) 714-670-1145

EUROPE
 2 Rue Goethe
 57430 Sarralbe
 France

Tel: (33) 3 87 97 31 01
 Fax: (33) 3 87 97 96 86

ASIA
 Units 602-603 6/F Lakeside 1
 No.8 Science Park West Avenue
 Phase Two, Hong Kong Science Park
 Pak Shek Kok, Tai Po, N.T.
 Hong Kong
 Tel: (852) 2 191 3830
 Fax: (852) 2 389 5803

Data sheets are for initial product selection and comparison. Contact Esterline Power Systems prior to choosing a component.

COIL CHARACTERISTICS (Vdc)**SERIES Z, ZD**

CODE	A	B	C	F Vac 400 Hz	N [6]	Y [9]	YN [6]
Nominal operating voltage	28	12	6	115	28	28	28
Maximum operating voltage	29	14.5	7.3	124	29	29	29
Pick-up voltage, maximum							
- Nominal	18	9	4.5	90	18	18	18
- High temp test	20	10	5	95	20	20	20
- Continuous current test	22.5	11	5.7	100	22.5	22.5	22.5
Drop-out voltage, maximum	7	4.5	2.5	30	7	7	7
Coil resistance in Ohms $\pm 10\%$ at +25° C	113	28	7	-	113	-	-
Coil current Amp max. @ Nom. Volt. and +25° C	0.31	0.60	1.20	0.12	0.31	6/68	6/68

GENERAL CHARACTERISTICS

Temperature range	-55°C to +71°C
Minimum operating cycles (life) at rated resistive load	50,000
Minimum operating cycles (life) at 25% rated resistive load	100,000
Dielectric strength at sea level	
- All circuits to ground and circuit to circuit	1500 Vrms
- Coil to ground and Aux.contacts	1250 Vrms
Dielectric strength at altitude	700 Vrms (Main contacts) 500 Vrms (Coil and auxiliary contacts)
Insulation resistance	
- Initial (500 Vdc)	100 M Ω min
- After environmental tests (500 Vdc)	50 M Ω min
Sinusoidal vibration (55 to 1000 Hz)	10 G
Shock (10-12 ms duration)	15 G
Maximum contact opening time under vibration and shock	10 μ s
Operate time at nominal voltage (Including bounce)	60 ms max 25 ms max (Economizer coil)
Release time at nominal voltage (Including bounce)	
- DC	40 ms max
- AC	125 ms max
Release time at nominal voltage (Including bounce) : Economizer coil	
- DC	35 ms max

GENERAL CHARACTERISTICS CONTINUED

SERIES Z, ZD

Contact bounce at nominal voltage	4 ms max
Weight	Noted
Overload	800 Amps @ 115/200 Vac, 400 Hz
Rupture	1200 Amps @ 115/200 Vac, 400 Hz
Altitude	50,000 Feet

NOTES

- [1] Auxiliary contact rating - see page 5, note [2].
- [2] Inductive load life, 20,000 cycles.
- [3] Ratings are for double break/double make terminal type 6.
- [4] Alternate contact configurations and other special models available upon request. Please contact factory.
- 5. Terminal strength per para. 3,4,8,2,1 of MIL-R-6106F, Dated 8-25-67.
- [6] Suppressed back EMF suppression to 62 Volts max.
- [7] Suitable for transfer between unsynchronized AC power sources at rating shown.
- [8] 200 Amps resistive, 25,000 cycles only, terminal style 6.
- [9] Economizer coils have a lower resistance primary coil for faster operate time. Once relay operates, the coil switches to a higher resistance for lower power drain. Do not ramp up voltage on these coils.
- [10] Non hermetic gasket sealed version.
- 11. This series drawing is for general use only. Please consult factory for special requirements.

NUMBERING SYSTEM

	Z	- X	O	X
	[10]	ZD	- X	O X
Relay family _____				
1-Mounting Style(A,B,Etc.) _____				
2-Terminal & Circuit(1,2,3 Etc.) _____				
3-Coil Voltage(A,B,C,F,N,Y,YN) _____				

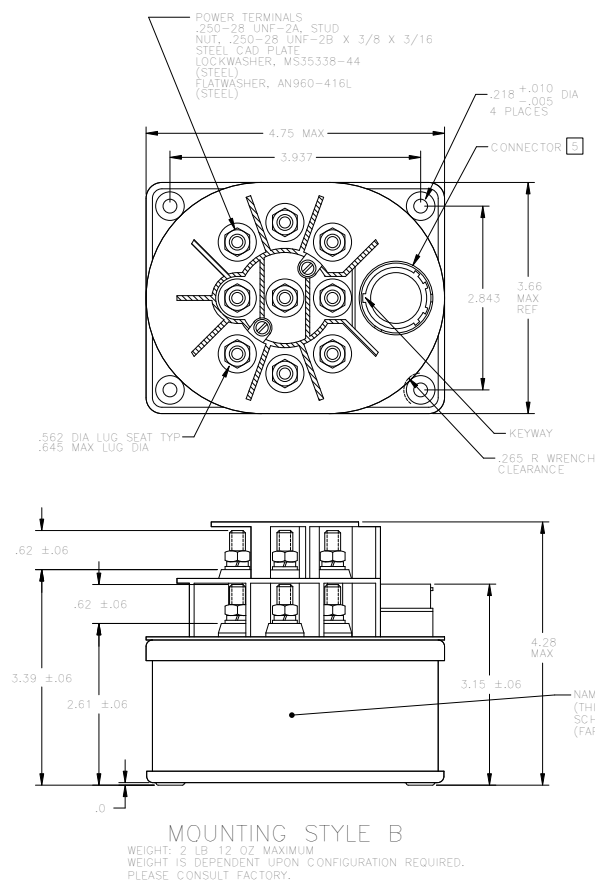
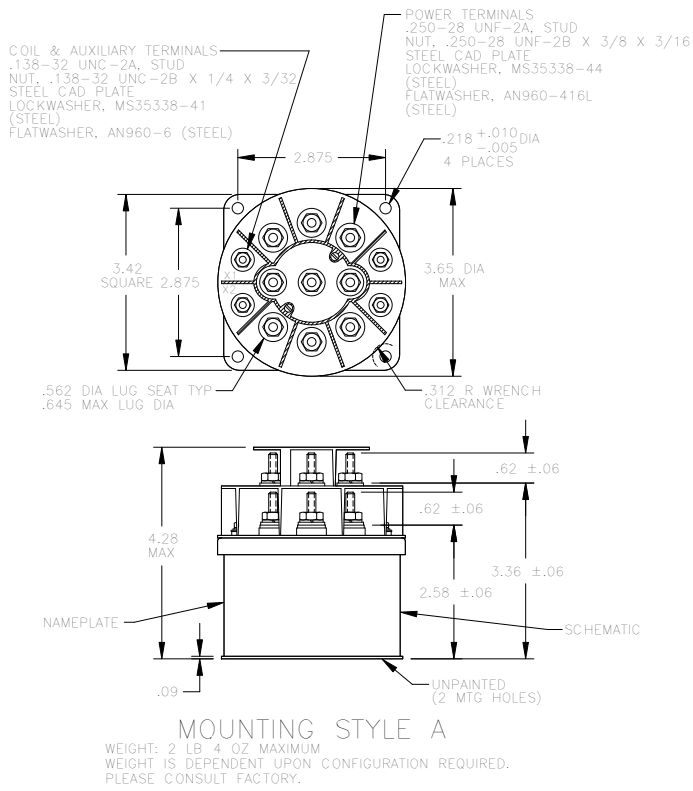

MOUNTING STYLE H
 WEIGHT: 2 LB 8 OZ MAXIMUM

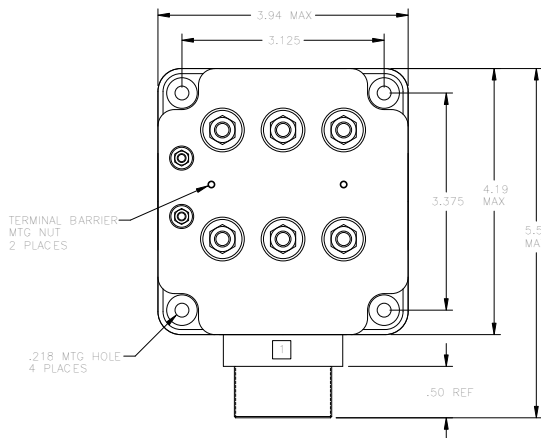

MOUNTING STYLE K
 WEIGHT: 2 LB 13 OZ MAXIMUM

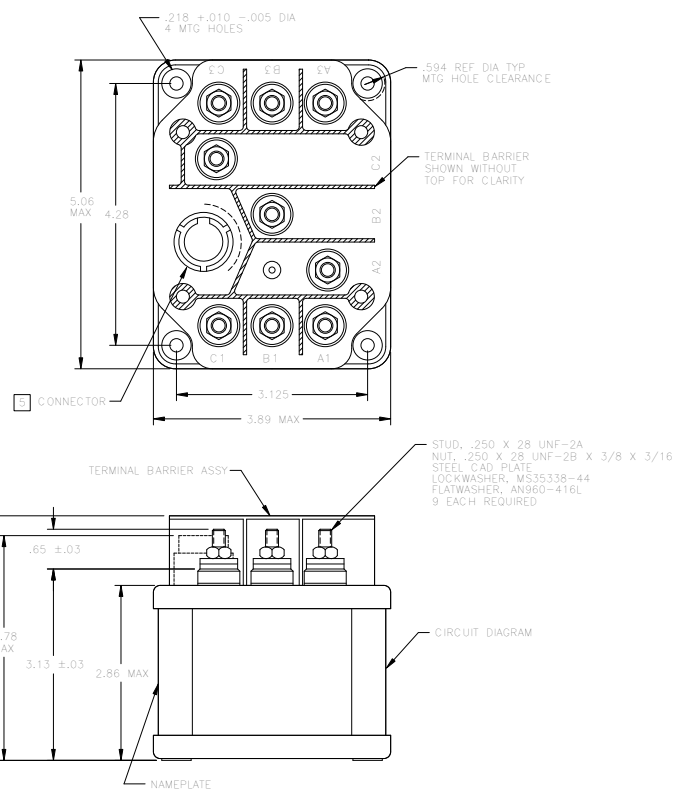

COIL CIRCUIT CONFIGURATION [3] [4]

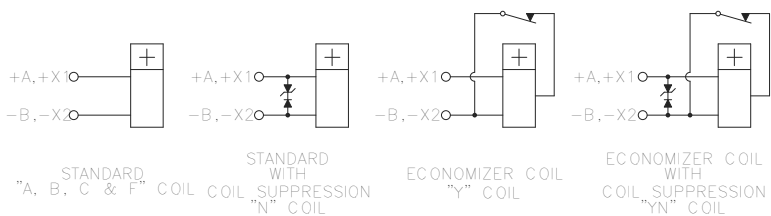

NOTES:

- [1] CAN BE DELETED.
- [2] MAXIMUM DIMENSIONS CAN BE REDUCED BY .500 INCH.
- [3] POLARITY INDICATION APPLIES TO D.C. COILS ONLY.
- [4] COIL TERMINALS MAY BE IDENTIFIED AS A-B, X1-X2, Y1-Y2 OR X-Y.

STANDARD TOLERANCE: XX ± .03, XXX ± .010

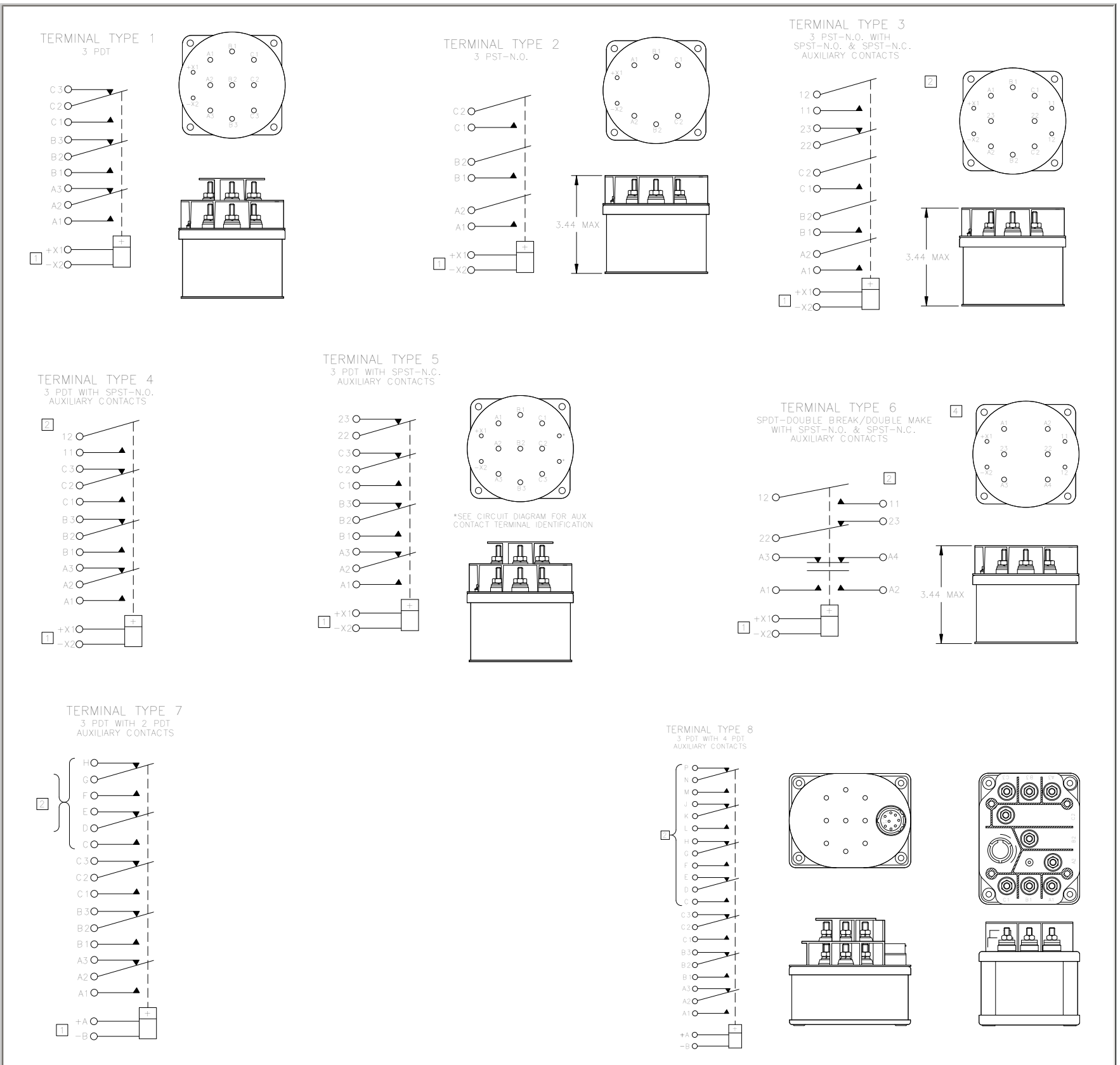

TERMINAL TYPE 9
IS A GENERAL CATEGORY USED FOR ALL TERMINAL TYPES NOT ILLUSTRATED. FOR OTHER VARIATIONS OF TERMINAL CONFIGURATIONS—PLEASE CONTACT FACTORY.

- 1 POLARITY INDICATION APPLIES TO D.C. COILS ONLY
- 2 AUXILIARY CONTACT RATING 28 VDC OR 115 VAC
 RESISTIVE 5 AMP
 INDUCTIVE 3 AMP
 LAMP 1 AMP
 BOUNCE AT NOMINAL VOLTAGE .004 SEC MAX
 OTHER AUXILIARY CONTACT FORMS AVAILABLE, INCLUDING LOW LEVEL CAPACITY
- 3 AVAILABLE IN "A" AND "H" MOUNTING
- 4 AVAILABLE IN "A" AND "B" MOUNTING

NOTE: Although all configuration and/or terminal type options are available, some combinations may require a setup charge and be subject to minimum order size.